

# Service Schematics

## NOKIA 3110 CLASSIC

### RM-237



## Introduction

### **Important:**

This document is intended for use by authorized service centers only.

“Service Schematics” was created with focus on customer care. The purpose of this document is to provide further technical repair information for NOKIA mobile phones on Level 3/4 service activities. It contains additional information such as e.g. “Component finder”.

Saving process time and improving the repair quality is the aim of this document. It is to be used additionally to the service manual and other training or service information such as Service Bulletins.

While every endeavour has been made to ensure the accuracy of this document, some errors may exist. If the reader finds any errors, NOKIA should be notified in writing.

Please send E-Mail to: [training.sace@nokia.com](mailto:training.sace@nokia.com)

### Table of contents

Frontpage	1
System connector	2
RETU, SIM, Audio	3
TAHVO	4
RAP3G, Combo memory & microSD	5
FM radio & Bluetooth	6
User interface & camera	7
RF part	8
Component finder	9

Copyright © NOKIA

This material, including documentation and any related computer programs is protected by copyright, controlled by NOKIA. All rights are reserved. Copying, including reproducing, modifying, storing, adapting or translating any or all of this material requires the prior written consent of NOKIA. This material also contains confidential information, which may not be disclosed to others without the prior written consent of NOKIA.

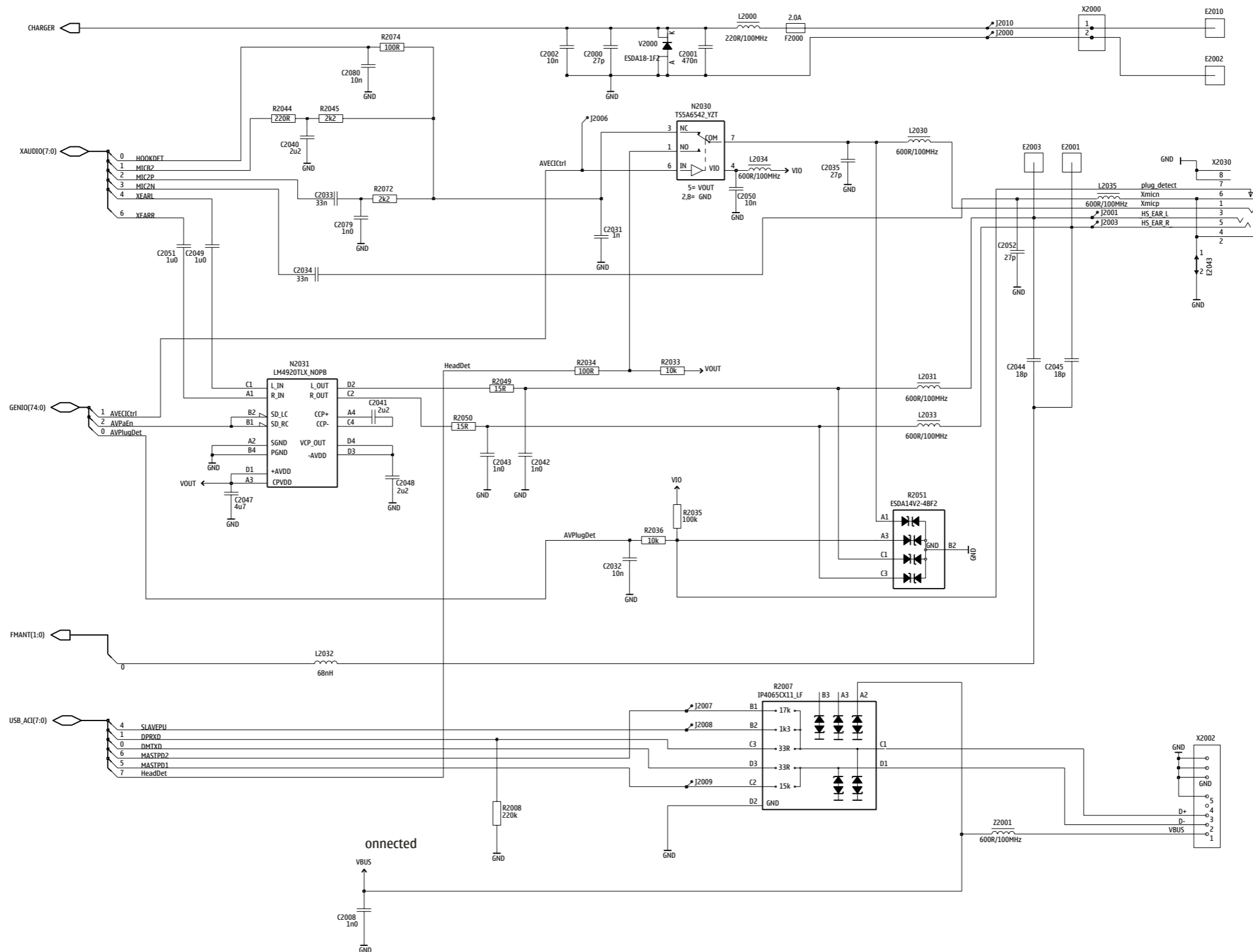

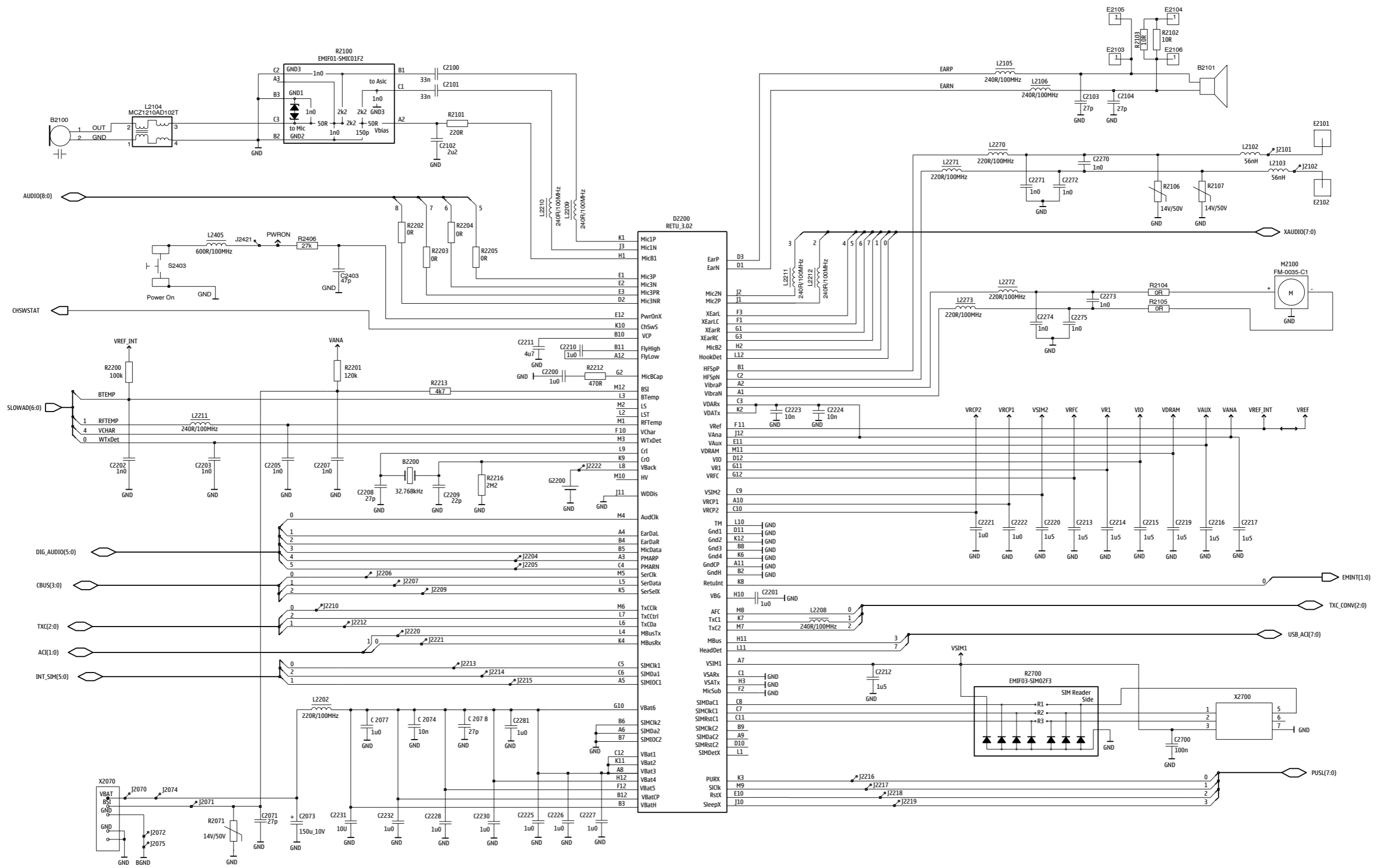

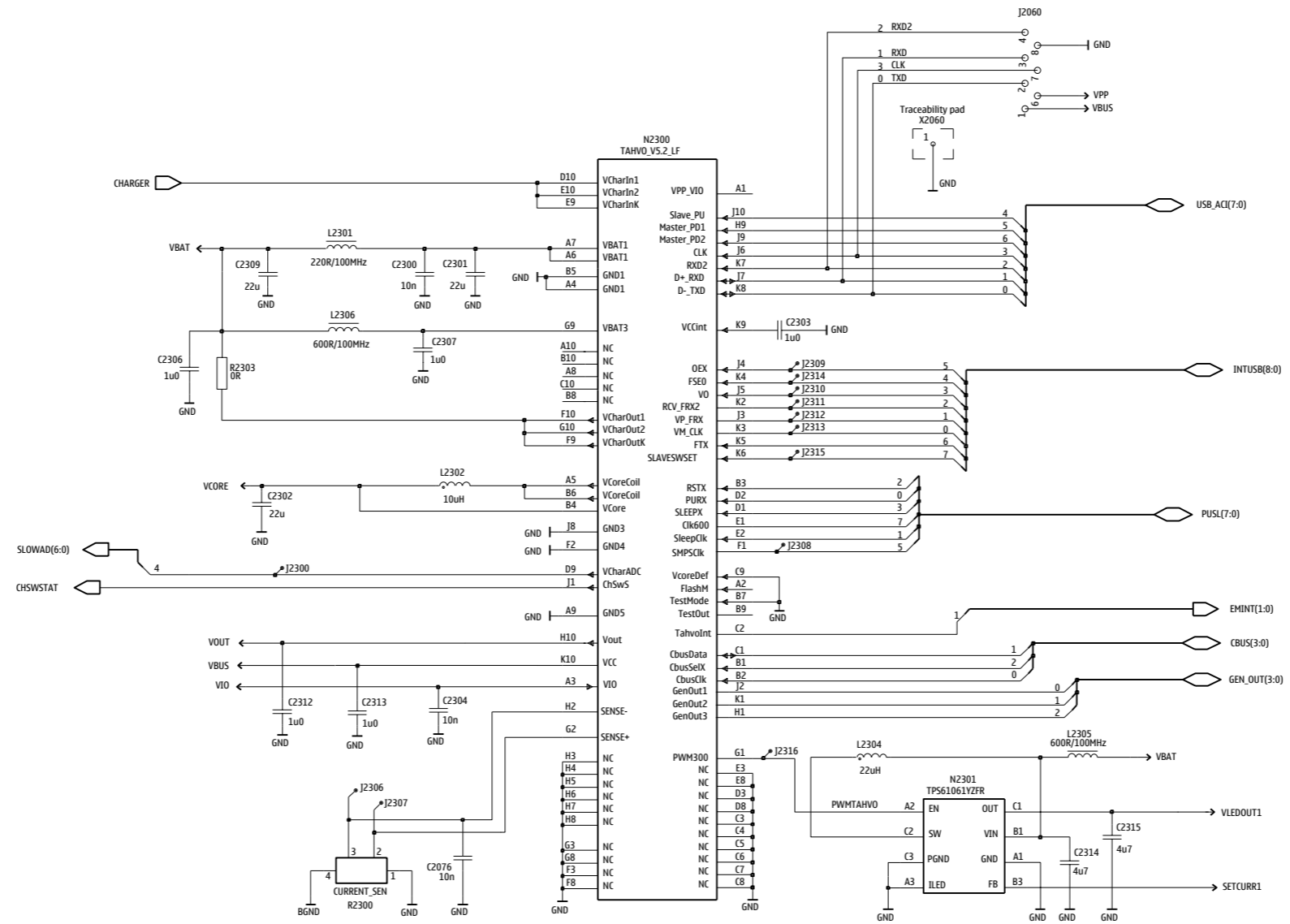



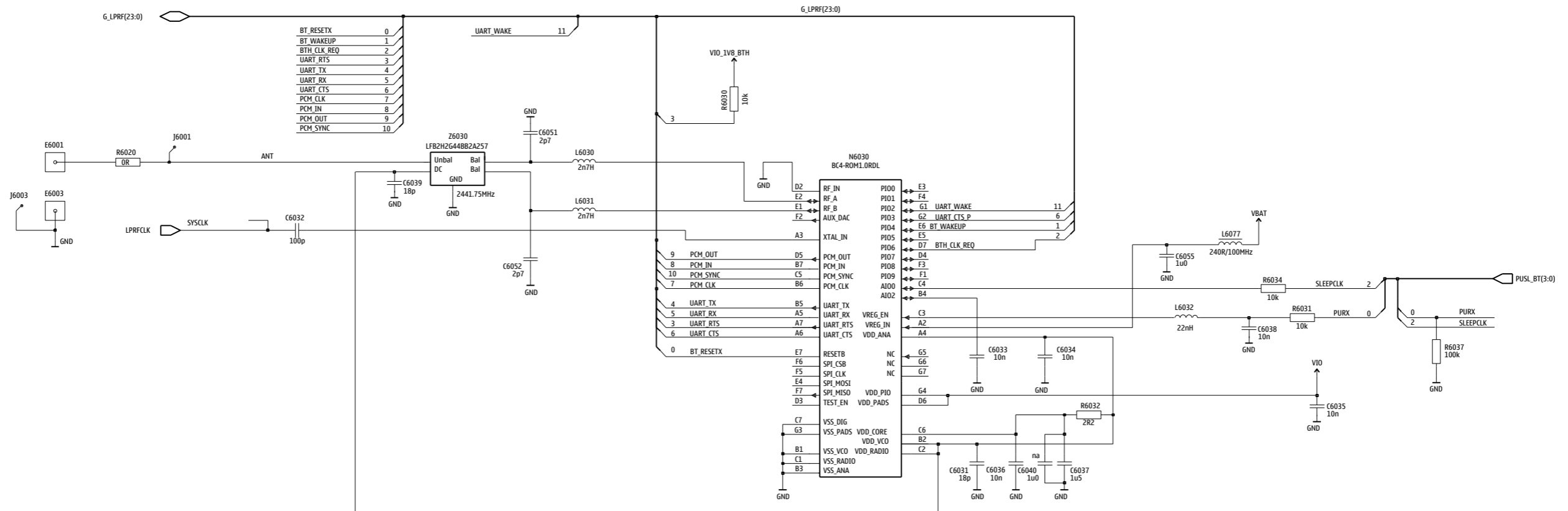
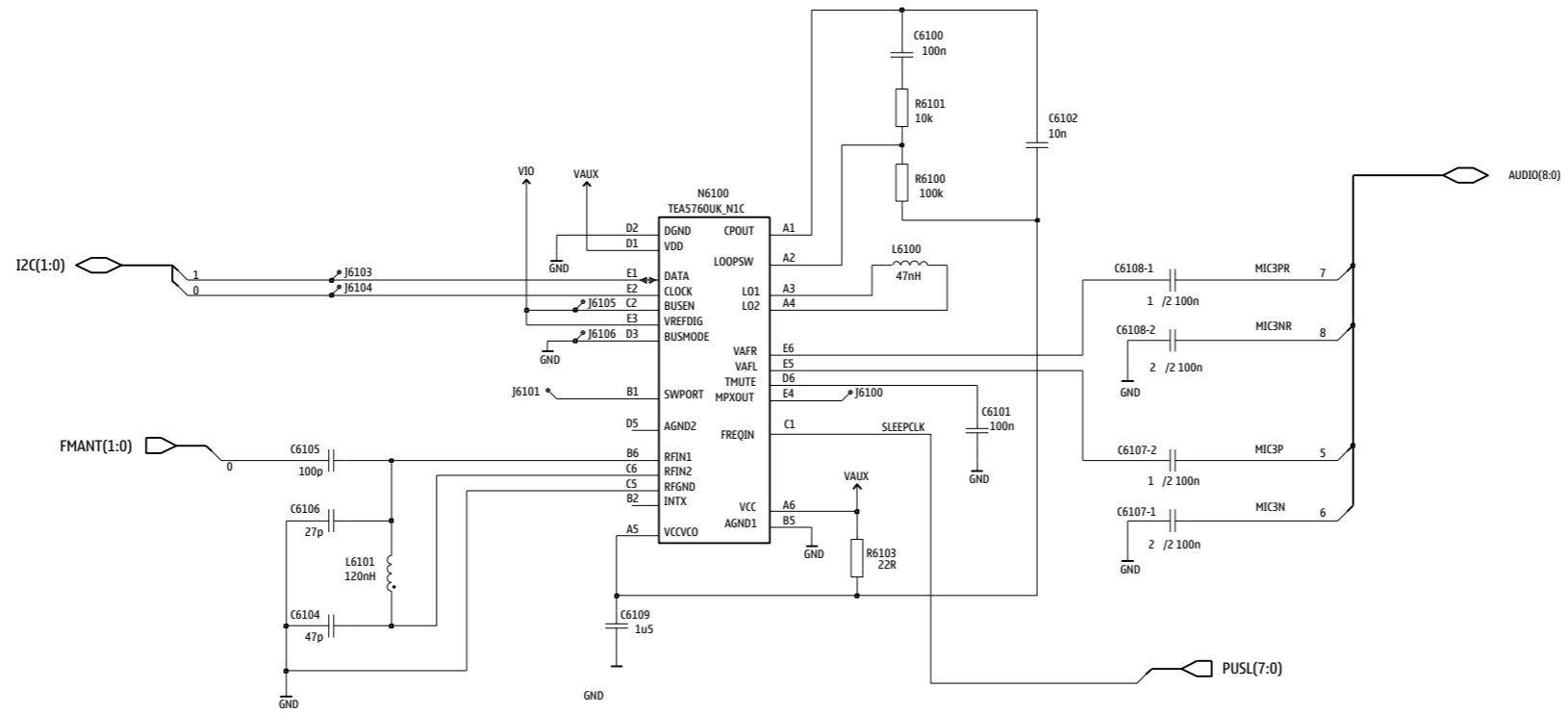

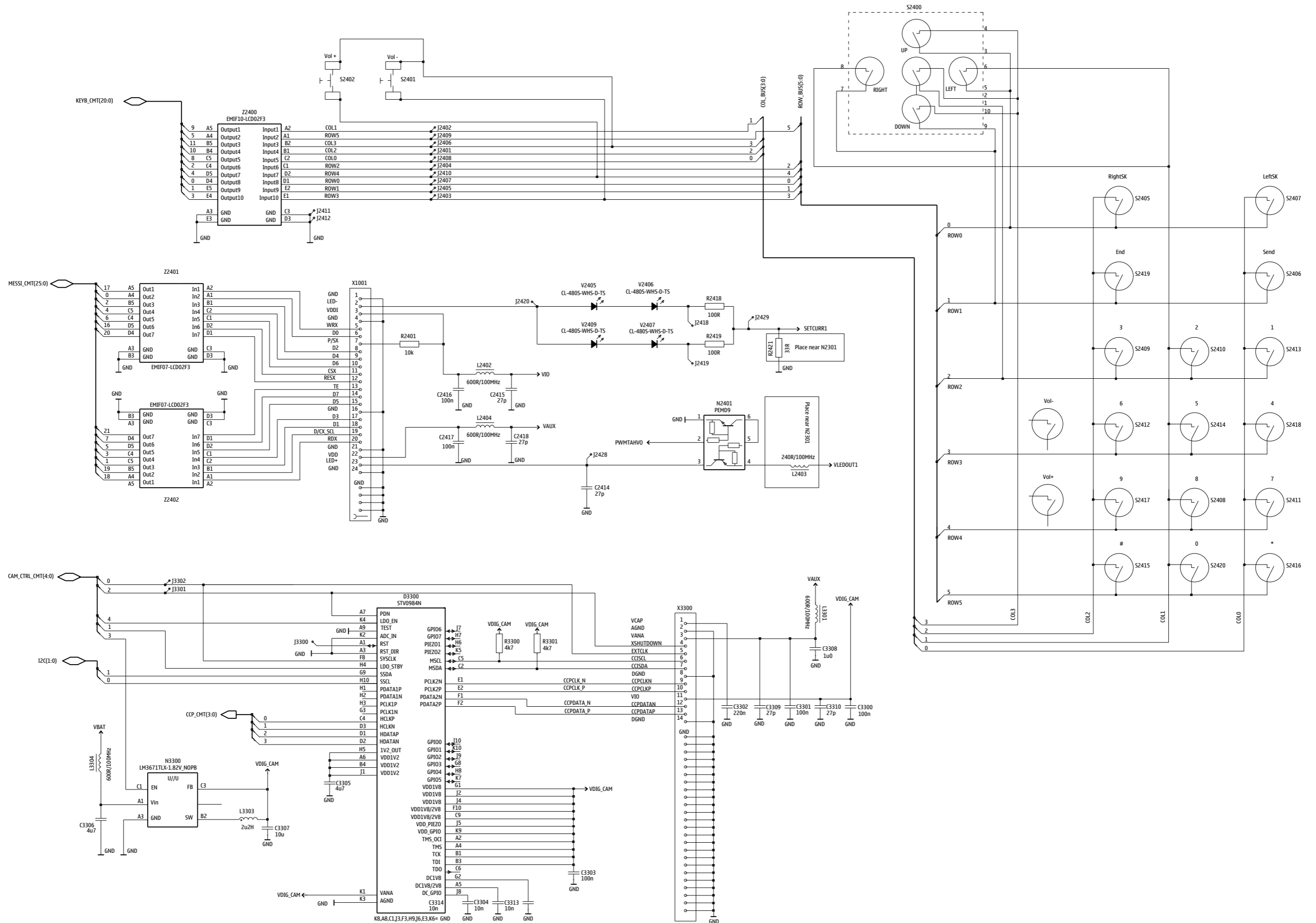

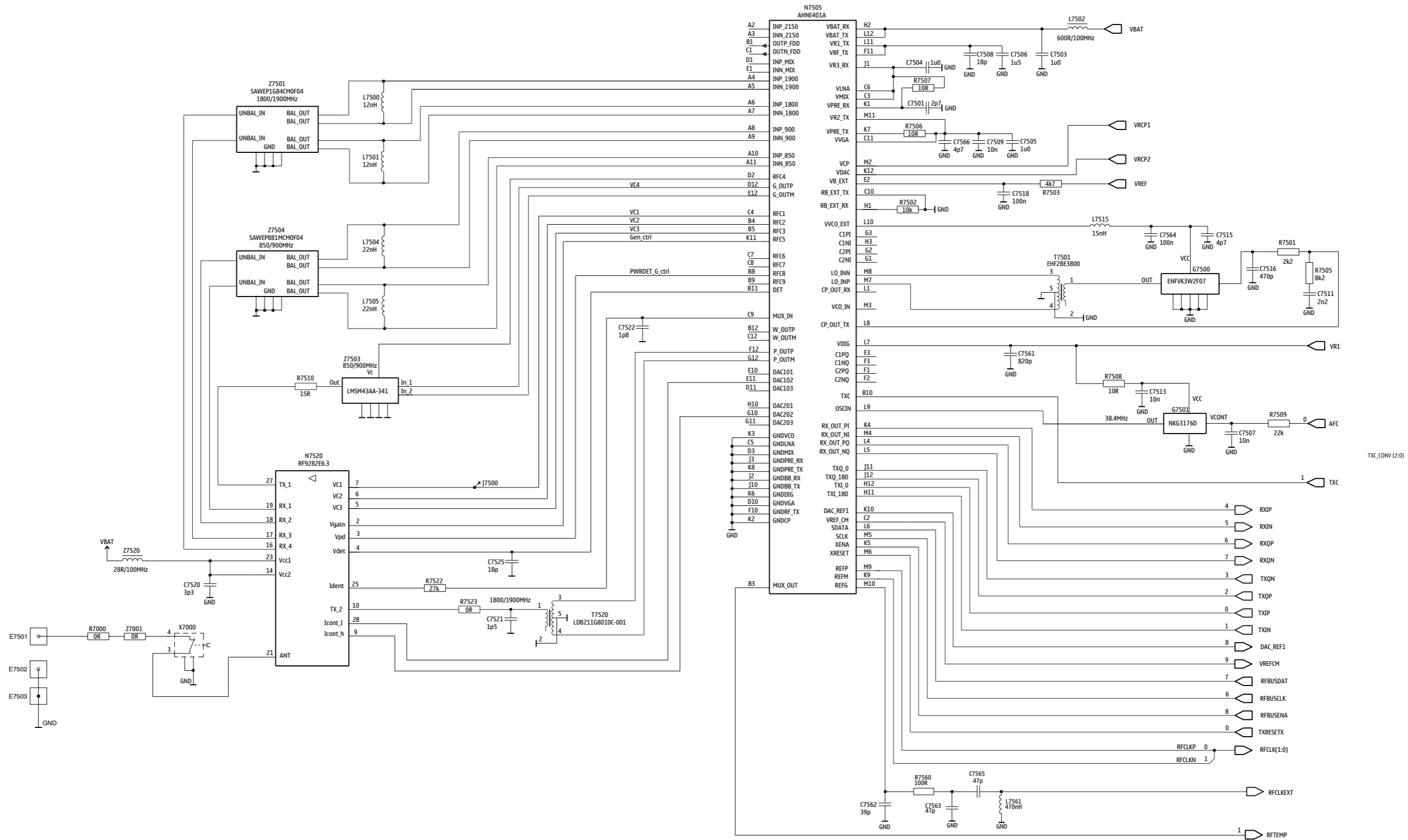



B	C2274	K4	C3300	P7	E2003	D5	J2209	I6	L2034	D5	R2072	E5	S		
B2100	B8	C2275	K5	C3301	N5	E2010	A7	J2206	I6	L2035	C7	R2074	E5	S2401	O2
B2101	T7	C2281	L2	C3302	N5	E2070	P3	J3001	I7	L2102	Q5	R2100	G5	S2402	S2
B2200	M3	C2300	J4	C3303	O8	E2071	P4	J3003	I7	L2103	Q8	R2101	H6	S2403	U5
C	C2301	I5	C3304	O8	E2075	P4	J3000	I8	L2104	G6	R2102	U7	T		
C2000	A4	C2302	K5	C3305	O7	E2101	Q7	J2428	J2	L2105	O2	R2103	U7	T6000	R2
C2001	B4	C2303	I3	C3306	O9	E2102	O9	J2309	J3	L2106	O2	R2104	F5	T6001	P2
C2002	B3	C2304	K4	C3307	O8	E2103	U7	J2315	J3	L2202	M2	R2105	F5	T6002	P2
C2008	C3	C2305	I2	C3308	N6	E2104	T6	J2310	J3	L2207	M5	R2106	N5	T6003	P2
C2030	E5	C2306	I4	C3309	N5	E2105	U7	J2312	J3	L2208	M5	R2107	N5	T6004	Q2
C2031	E5	C2307	I4	C3310	P7	E2106	T7	J2219	J6	L2209	M5	R2200	N2	T6005	Q3
C2032	D5	C2309	I5	C3313	O8	E2401	C9	J3005	J8	L2210	M5	R2201	N3	T7501	R4
C2033	E5	C2312	I4	C3314	P8	E2402	C1	J3004	J8	L2211	N5	R2202	M5	T7520	S9
C2034	E5	C2313	I3	C6020	T2	E2403	N2	J2311	K3	L2212	N4	R2203	M5	V	
C2035	C6	C2314	J3	C6031	R2	E2405	T9	J2313	K3	L2270	L5	R2204	M5	V2000	B4
C2040	H6	C2315	K2	C6032	P3	E2407	N9	J2314	K3	L2271	L5	R2205	M5	V2405	G4
C2041	C4	C2317	J2	C6033	P3	E2506	T2	J2316	K3	L2272	K4	R2212	L5	V2406	G7
C2042	D4	C2403	N2	C6034	P3	E6001	T2	J2217	K4	L2273	K5	R2213	N3	V2407	B7
C2043	C4	C2404	T3	C6035	P2	E6003	T2	J2216	K4	L2301	I5	R2216	N3	V2409	B4
C2044	C5	C2405	H5	C6036	P3	E7000	U8	J2218	K4	L2302	J5	R2250	N2	X	
C2045	D5	C2413	I2	C6037	P2	E7001	U5	J2300	K4	L2304	J3	R2251	N3	X1001	U3
C2046	C4	C2414	T3	C6038	Q2	E7501	T9	J2308	K4	L2305	I3	R2303	I4	X2000	A7
C2047	C4	C2415	T4	C6039	Q3	E7502	T9	J2214	K6	L2306	I3	R2401	T4	X2002	B3
C2048	C3	C2416	T4	C6040	P2	E7503	U8	J2213	K6	L2402	T4	R2406	N2	X2030	B5
C2049	H5	C2417	T3	C6051	Q3	F	J2215	K6	L2403	J2	R2418	H5	X2060	A4	
C2050	D5	C2418	T3	C6052	Q2	F2000	B7	J2207	K6	L2404	T3	R2419	H5	X2070	G3
C2051	H5	C2600	H8	C6055	Q3	G	J3006	K8	L2405	O2	R2421	K3	X2700	G3	
C2052	C5	C2601	H9	C6100	G7	G2200	C2	J2212	L6	L3200	G8	R2422	G5	X3200	E8
C2071	Q4	C2602	G9	C6101	H6	G7500	S4	J2220	L6	L3301	N6	R2600	H8	X3300	P5
C2073	S3	C2603	H8	C6102	G7	G7501	Q4	J2221	L6	L3303	P9	R2803	L9	X7000	T8
C2074	L2	C2700	H3	C6103	G7	J	J3002	L6	L3304	O9	R2804	L9	Z		
C2076	Q4	C2701	H3	C6104	H6	J2000	A7	J2210	M4	L6030	Q2	R2830	N8	Z2001	C3
C2077	M2	C2800	L9	C6105	G6	J2010	A7	J2205	M4	L6031	Q2	R3000	J6	Z2400	H4
C2078	M2	C2801	N8	C6106	H6	J2408	B9	J2204	M5	L6032	Q2	R3002	L9	Z2401	U4
C2079	E5	C2802	M9	C6107	H7	J2401	C2	J2804	M6	L6077	R3	R3003	K7	Z2402	H3
C2080	E5	C2803	L9	C6108	H6	J2409	C2	J2803	M6	L6100	G7	R3004	K8	Z2700	H2
C2100	G5	C2804	N8	C6109	G7	J2412	C2	J3104	M9	L6101	H6	R3200	G8	Z6030	R2
C2101	G5	C2805	K6	C6111	N5	J2405	C9	J3102	M9	L7500	S7	R3201	H8	Z7001	T8
C2102	H6	C2807	N9	C6112	N5	J2406	C9	J3106	M9	L7501	S7	R3202	H8	Z7002	T9
C2103	O2	C2808	M9	C7000	U8	J2402	C9	J3105	M9	L7502	Q5	R3205	G8	Z7501	S7
C2104	O2	C2809	M9	C7001	T9	J2222	D2	J3107	M9	L7503	Q9	R3206	H8	Z7503	Q7
C2200	M5	C2810	K9	C7501	S5	J2404	D2	J3103	M9	L7504	R7	R3300	P7	Z7504	R7
C2201	M3	C2811	K6	C7502	Q5	J2403	D2	J2420	N2	L7505	R7	R3301	P8	Z7520	S8
C2202	N2	C2812	L9	C7503	Q5	J2410	D2	J2421	N2	L7515	S5	R3305	O7		
C2203	M4	C2813	N6	C7504	S5	J2007	D3	J2834	N6	L7561	Q6	R3306	P8		
C2204	M4	C2814	M9	C7505	Q5	J2008	D3	J2833	N6	M	R3307	P7			
C2205	M5	C2815	K9	C7506	Q5	J2009	D3	J2835	N6	M2100	C8	R3312	I8		
C2206	M4	C2816	K8	C7507	Q4	J2001	D4	J2852	N7	N	R3313	I9			
C2207	N3	C2818	K7	C7508	Q5	J2003	D5	J2829	N7	N2030	D6	R3314	O7		
C2208	N4	C2819	K8	C7509	R5	J2411	D9	J2830	N7	N2031	C4	R6005	N3		
C2209	N3	C2820	N7	C7511	R4	J2407	D9	J2851	N7	N2300	J4	R6020	T2		
C2210	K3	C2821	N7	C7513	Q4	J3114	E3	J2828	N7	N2301	J2	R6030	P3		
C2211	K3	C2830	N8	C7515	S5	J3115	E3	J2831	N7	N2401	G5	R6031	Q2		
C2212	K4	C2831	N8	C7516	S5	J3116	E3	J3100	N9	N2600	G9	R6032	P2		
C2213	L3	C3000	I6	C7518	Q5	J3117	E3	J3101	N9	N3200	G8	R6034	Q3		
C2214	L3	C3001	J6	C7520	S8	J3112	E3	J3301	O7	N3300	O9	R6037	Q2		
C2215	L2	C3002	J6	C7521	S8	J3113	E4	J3302	O8	N3301	O7	R6100	G7		
C2216	L2	C3003	K9	C7522	Q8	J1001	E4	J2074	P3	N6030	P2	R6101	G7		
C2217	M3	C3004	K9	C7523	S8	J1000	E4	J2070	P3	N6100	H7	R6102	H7		
C2219	M3	C3005	J9	C7524	Q8	J2006	E5	J2072	P4	N7505	R6	R6103	G6		
C2220	K4	C3006	I9	C7525	Q9	J2600	F6	J2071	P4	N7520	R8	R6104	G7		
C2221	K2	C3007	J9	C7560	R4	J3200	G8	J2075	P4	R	R6105	G7			
C2222	K3	C3008	J9	C7561	R4	J3201	G8	J3300	P8	R2007	C3	R7001	T8		
C2223	L5	C3009	I9	C7562	Q6	J3202	G8	J2306	Q4	R2008	C2	R7002	T9		
C2224	M5	C3010	N6	C7563	Q6	J3203	G8	J2307	Q4	R2033	E5	R7501	R5		
C2225	M3	C3013	K7	C7564	S5	J1	G9	J2101	Q8	R2034	E5	R7502	S6		
C2226	L3	C3014	K7	C7565	Q6	J2	G9	J2102	Q8	R2035	D6	R7503	Q5		
C2227	K3	C3100	E2	C7566	R5	J2429	H5	J6001	S2	R2036	D6	R7505	R4		
C2228	L3	C3115	O7	D	J2419	H5	J6003	S2	R2044	H6	R7506	R5			
C2230	M3	C3116	O7	D2200	L4	J6100	H7	J7500	T8	R2045	E5	R7507	S5		
C2231	K5	C3200	G8	D2800	L7	J6101	H7	L	R2049	D4	R7508	R4			
C2232	L3	C3201	H8	D3000	J7	J6103	H7	L2000	B4	R2050	C4	R7509	Q4		
C2270	L5	C3202	H8	D3300	O8	J6104	H7	L2030	C5	R2051	C6	R7510	Q9		
C2271	L5	C3203	G8	E	J6105	H7	L2031	C5	R2052	C4	R7522	Q8			
C2272	L5	C3210	G8	E2001	D4	J6106	H7	L2032	D6	R2070	E2	R7523	S9		
C2273	K4	C3211	D9	E2002	A7	J2418	I5	L2033	D5	R2071	N2	R7560	Q6		

